







## MECCA SHOWER MIXER



### SPECIFICATION

PRODUCT CODE	YSW2219-09B
WELS RATING	N/A
WATERMARK LICENSE	WM-060073
TEMPERATURE RATING	MIN 1°C-MAX 75°C
PRESSURE RATING	MIN 150KPa-MAX 500KPa

### FINISH

	NR221909bCH	chrome
	NR221909bMB	matte black
	NR221909bBN	brushed nickel
	NR221909bGM	gun metal
	NR221909bBG	brushed gold
	NR221909bBZ	brushed bronze

### MAINTENANCE AND CARE

All surfaces should be cleaned with mild liquid detergent or soap and water.

Do not use cream cleaners or citrus based cleaning products, as they are abrasive.

Use of unsuitable cleaning agents may damage the surface. Any damage caused in this way will not be covered by warranty.

### PACKAGING INCLUDES

- 1x body set
- 1x handle
- 1x plate
- 1x accessories pouch

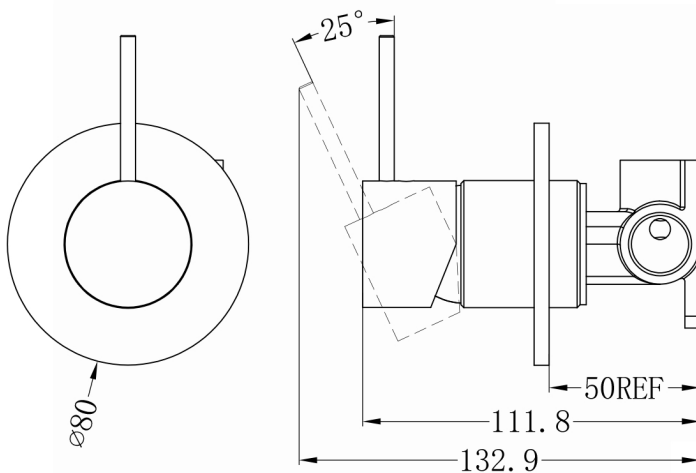

Dimensions are nominal measurements only.



## INSTALL INSTRUCTION

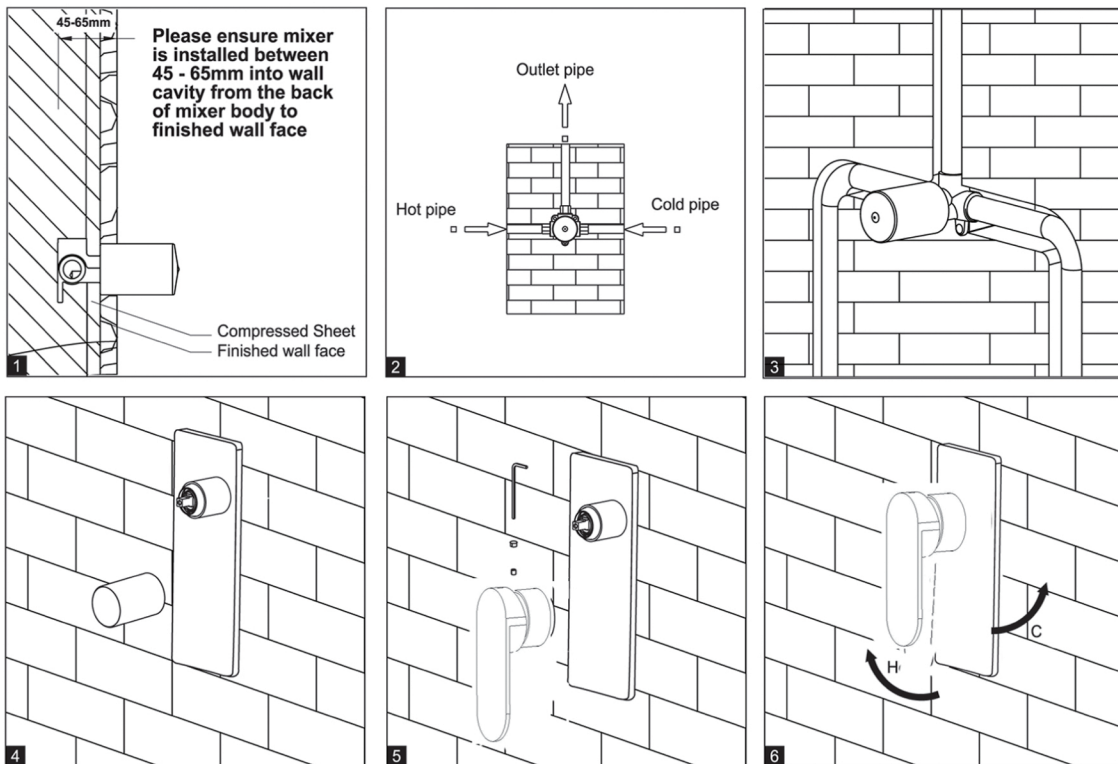

1. Install mixer body into wall cavity. Refer to diagram 1 above for setting depth of mixer body in relation to finished wall face.
2. Connect all pipe work as per diagram 2 above.
3. Pressure test for leaks then proceed to waterproof installation.
4. Remove protective sleeve and install decorator plate.
5. Install handle.
6. Operate mixer.

## EXPLOSIVE VIEW

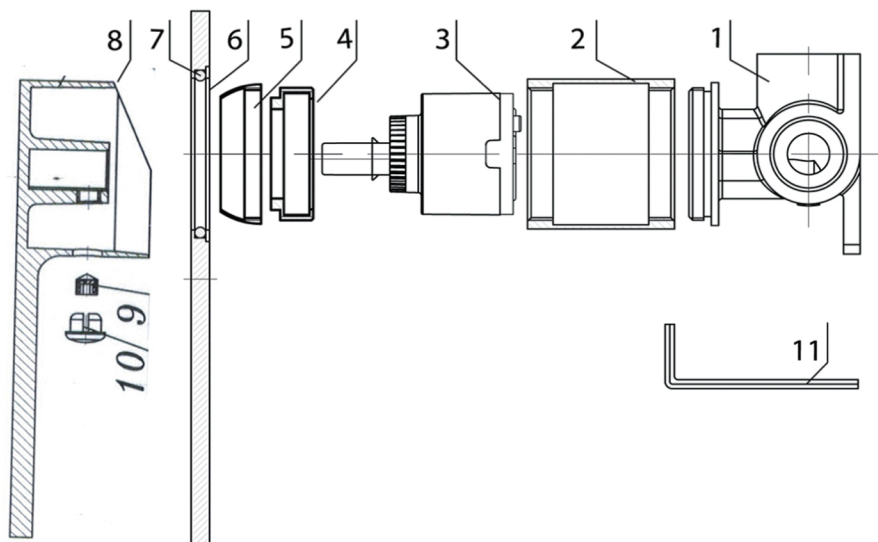

1. Body
2. Mixer body
3. Cartridge
4. Retaining nut
5. Cartridge cover
6. Backing plate
7. O-ring
8. Handle
9. Grub screw
10. Cap
11. Allen key