





MECCA WALL BASIN MIXER



SPECIFICATION

PRODUCT CODE	YSW2219-07B
WELS RATING	5 STAR 6L/MIN
WATERMARK LICENSE	WM-060073
TEMPERATURE RATING	MIN 1°C-MAX 75°C
PRESSURE RATING	MIN 150KPa-MAX 500KPa

FINISH

	NR221907b (160/185/230) CH chrome
	NR221907b (160/185/230) MB matte black
	NR221907b (160/185/230) BN brushed nickel
	NR221907b (160/185/230) GM gun metal
	NR221907b (160/185/230) BG brushed gold
	NR221907b (160/185/230) BZ brushed bronze

MAINTENANCE AND CARE

All surfaces should be cleaned with mild liquid detergent or soap and water.

Do not use cream cleaners or citrus based cleaning products, as they are abrasive.

Use of unsuitable cleaning agents may damage the surface. Any damage caused in this way will not be covered by warranty.

PACKAGING INCLUDES

- 1x mixer body
- 1x handle
- 1x spout
- 1x plate
- 1x accessories pouch

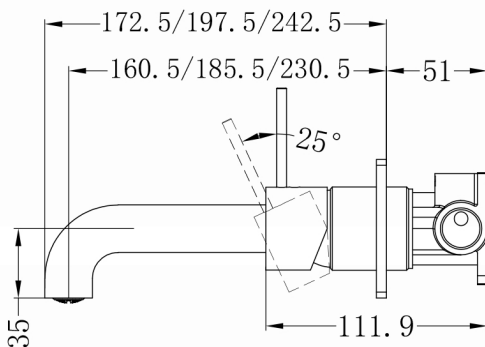
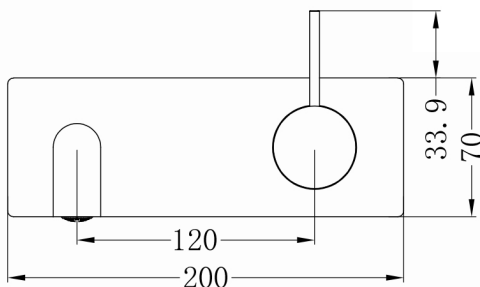

Dimensions are nominal measurements only.



Versions: 2021.06

INSTALL INSTRUCTION

IMPORTANT: Please read all of the instructions before installation.

General:

1. Nero recommends this product is installed by a licensed plumber in compliance with all relevant regional regulations.
2. Do not hydrostatic test the installation with this mixer installed. Damage to the ceramic cartridge may occur.
3. All pipe work must be thoroughly flushed prior to the installation of the mixer.
4. Do not remove the ceramic cartridge from the mixer when installing.
5. After installation all connections must be checked for leaks.
6. All outlets used primarily for personal hygiene shall deliver water at a safe temperature as per regional regulations.
7. This mixer is not recommended for use in uncontrolled heating systems such as wet-backs or solar heating units unless a suitable tempering valve is fitted.
8. It is the responsibility of the installer to ensure a waterproof seal is achieved between the product and mounting surface. If in doubt about the quality of the seal, remove the product and reinstall.

Steps:

Diagram 1A

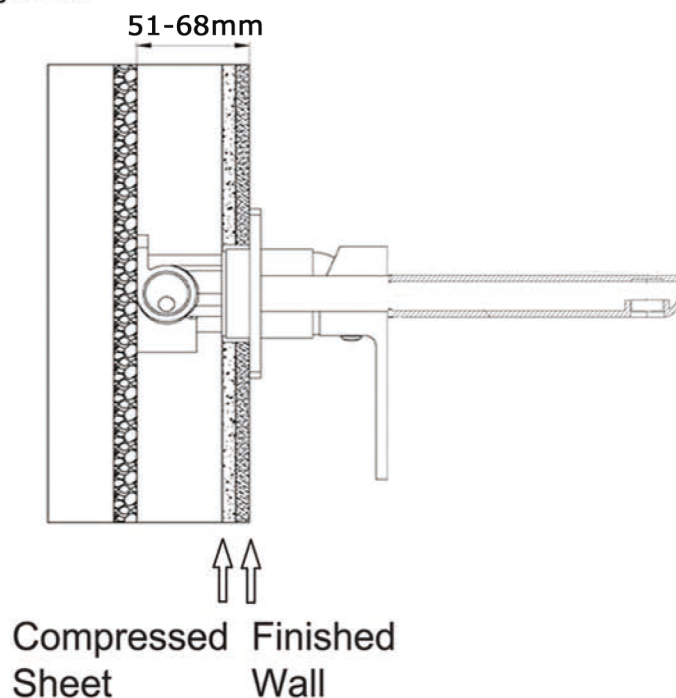

1. Proceed to mount complete assembly refer to above diagram 1A for setting assembly depth.
2. Connect hot and cold pipes to concealed valve.
3. Pressure test for leaks.
4. Water proof installation then proceed to fit off decorating plate, spout and handle.