

Assembly and installation instructions for the LIFE Urinal with the Schell COMPACT RD electronic sensor urinal valve

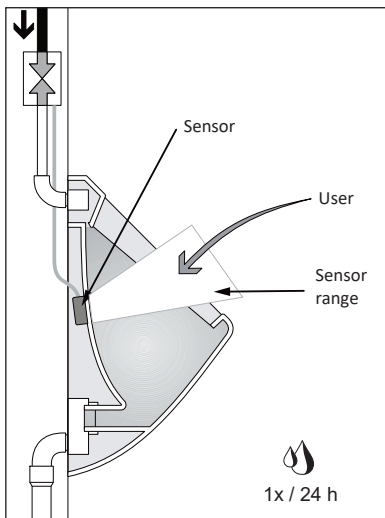

Operation Description

The Compact RD uses a Radar Detection system to detect the movement of a user.

The system is unaffected by common ambient influences such as light, people passing by and nearby structures.

The system also includes a programmed self sensing stadium mode and a periodic stagnation/hygiene flush.

Flushing volume can be adjusted to deliver 0.6 - 6L of water in a single flush

Technical Data

- Flow pressure: 50 - 500kPa
- Flow rate: 0.3l/sec
- Power supply: 240V 50/60Hz
- Output: 7.5V 1A
- Noise class II
- Protection class: IP64
- Stagnation/hygiene flush: 20sec - 24 hours after last use
- Automatic stadium mode

E-Module and sensor: Conformity with R & TT 1999/05/EC, EMC 89/336/E

Scope of supply

- Solenoid valve
- Compact rough-in set with air-break
- RD Electronic sensor/control module
- Power supply
- Cables*
- Adhesive
- Screwdriver

* All supplied cables are 5m long.



Operation Sequence

1. Use urinal.
2. Approximately 5 seconds dwell time elapses after moving away.
3. Flush operation.
 Flush is adjustable 2-20 seconds (see p4).
 Factory flush setting - 20 seconds.
 Flushing is locked for approximately 8 seconds after each flush.

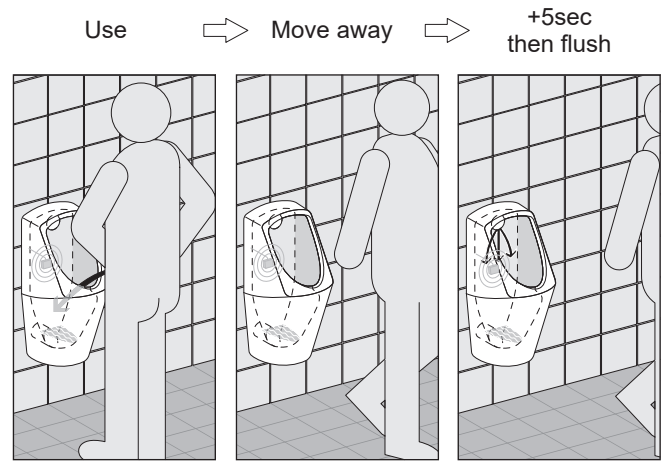

Note:

- Stadium mode will automatically commence when there are >3 uses within 4 minutes.
- Stadium mode operates 1 flush/minute.
- Stadium mode will finish when no use is detected for 5 minutes.
- A 20 sec stagnation/hygiene flush operates every 24 hours of non-use.

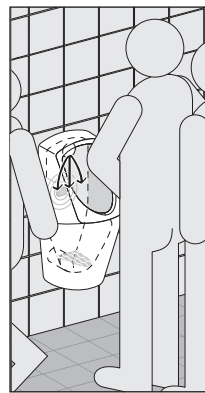

Component list

1. Compact rough-in set with air break
2. Power supply
3. Solenoid valve
4. Sensor/control module
5. Flush pipe (not included)
6. Power connecting cable
7. Solenoid connecting cable
8. Conduit (not included)

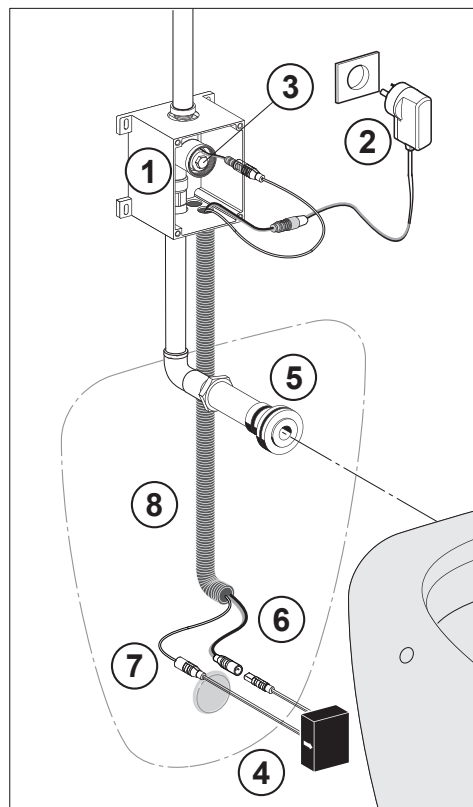

Assembly

1. Complete the water supply connection to the flush valve.

Important: the flush valve must be installed vertically and the lines must be flushed prior to fitting the solenoid valve.

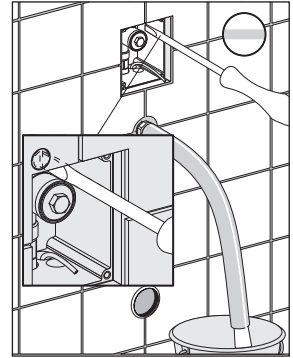
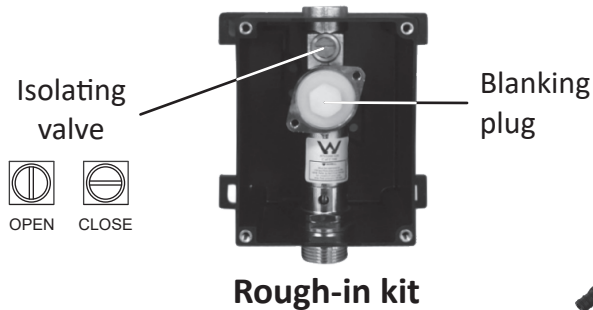

2. Remove the white plastic blanking plug from the solenoid cavity

3. Screw in the solenoid valve - hand tighten only

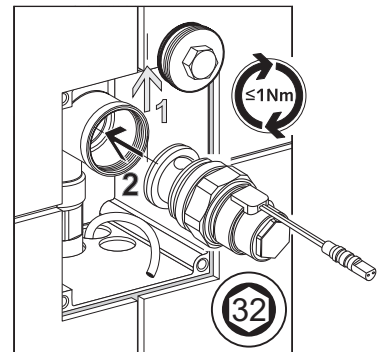

4. Pull the extension cables through the conduit - note that the conduit must have no kinks in it

5. Connect the extension cables to the sensor, power supply and solenoid

6. Connect the supply transformer to power point. **Important** - ensure that the correct wiring connections are made prior to installing the urinal.

Note: Surge protectors are recommended to avoid power spikes affecting the life of the transformer and control module

Sensor Installation

1. Locate and clean the fixing location of the sensor on the ceramic piece. Mark the location with a felt tip pen.

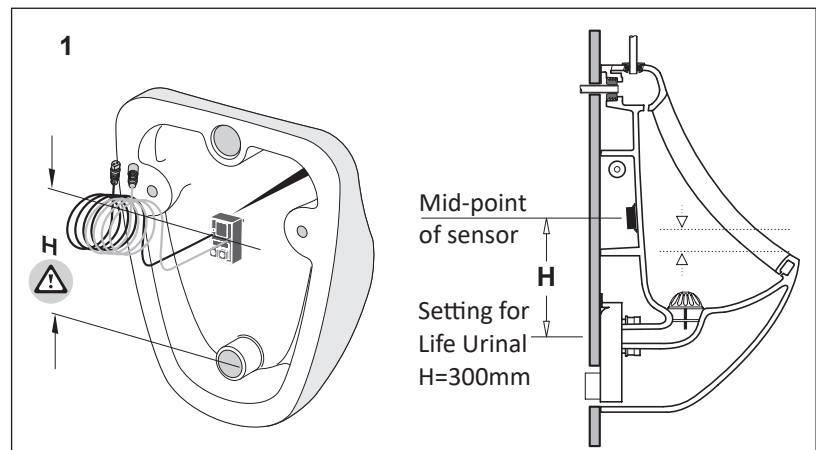

2. Cut and apply the strip adhesive **only to the sides of the sensor housing** - there must be **no adhesive between the sensor housing and the urinal wall**

3. Press the sensor module firmly into position and hold in place for approximately 20 seconds

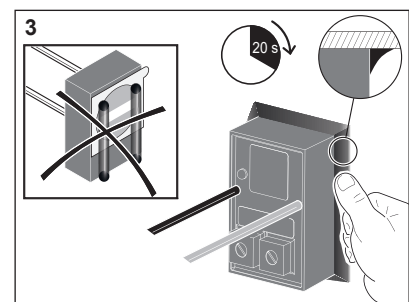
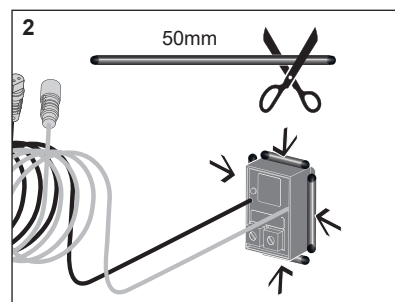

IMPORTANT:

The sensor must be placed at the back of the urinal, at a level above the height of the front of rim of the urinal (as per 'H' dimension)!

Sensor Adjustment

1. LED indicator light
2. Use the screwdriver supplied to adjust the radar sensitivity (range 0 - 50 centimetres)
Set at approximately 40cm.
3. Use the screwdriver supplied to adjust the flush time (2 - 20 seconds)
Note: for a single stall set the timer to ~5 seconds

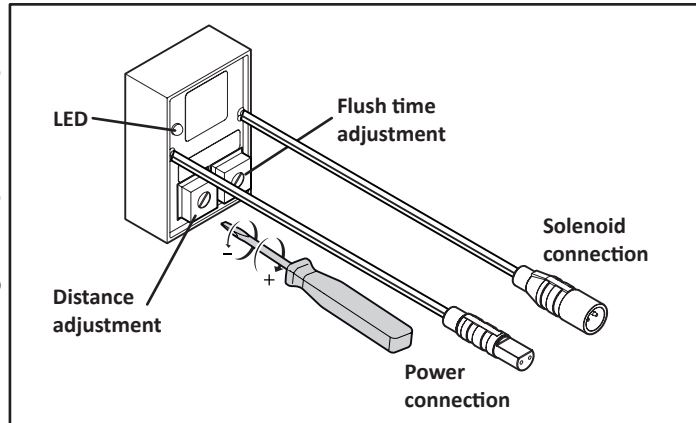

Commissioning

Function Test (Dry)

1. Close the isolating valve
2. Ensure that the power supply is OFF
3. Check that all cables are properly connected
4. Turn the power supply ON
5. Within 60 seconds of power on, move your hand in front of the sensor position and verify that the LED turns on. This confirms correct operation
6. Turn OFF the power supply while mounting the ceramic urinal

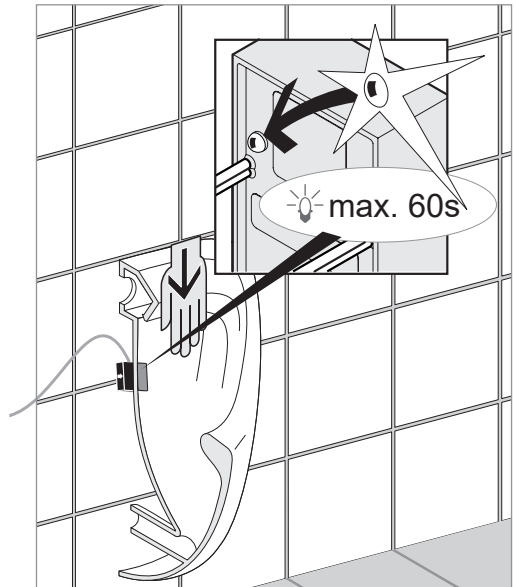

Function Test (Wet)

With the urinal fitted in position, connected and power on, conduct the following test:

1. Turn isolating valve on.
2. Using a suitable container pour approximately 100-150ml into the urinal bowl in the sensor area.
3. Flushing will occur after a time delay of approximately 5 seconds.
4. After approximately 8 seconds (lock period after flush) repeat the test.
5. In the event of a malfunction refer to the error checklist - P. 5

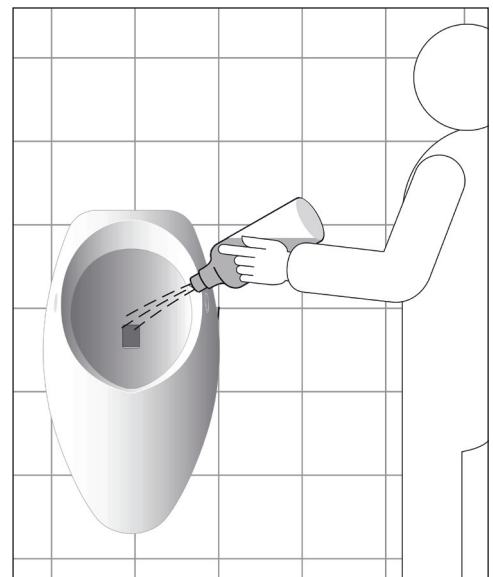

Error Checklist

Fault	Possible cause	Remedy
Not flushing	No water	Open isolating valve
	No power supply	Check mains connection and plug in connections
	Insufficient test water quantity	Pour approx 100-150ml water into urinal
	Test interval too short	Time difference after flushing (water still running) approx 8s.
	Sensor not mounted correctly	Check position and direction of arrow of sensor
	Sensor sensitivity not correct	Increase sensor sensitivity
	Water running for too long	Install supply set with backflow preventer, if necessary replace solenoid valve
Continuous flow	Flow pressure too low	Open isolating valve (min. 0.5bar)
	Sensor module placed too low	Refer to correct installation in P.3
	Incorrect application of the adhesive that holds sensor in place	Ensure the adhesive is NOT applied between the sensor and the ceramics, but around the sensor housing. refer to P.3 for correct installation.
	Solenoid valve defective	Replace
Insufficient flushing	Flow pressure too low	Open isolating valve (min. 0.5bar)
	Flush time too short	Adjust the flush time

Typical installation solutions

Inwall installation

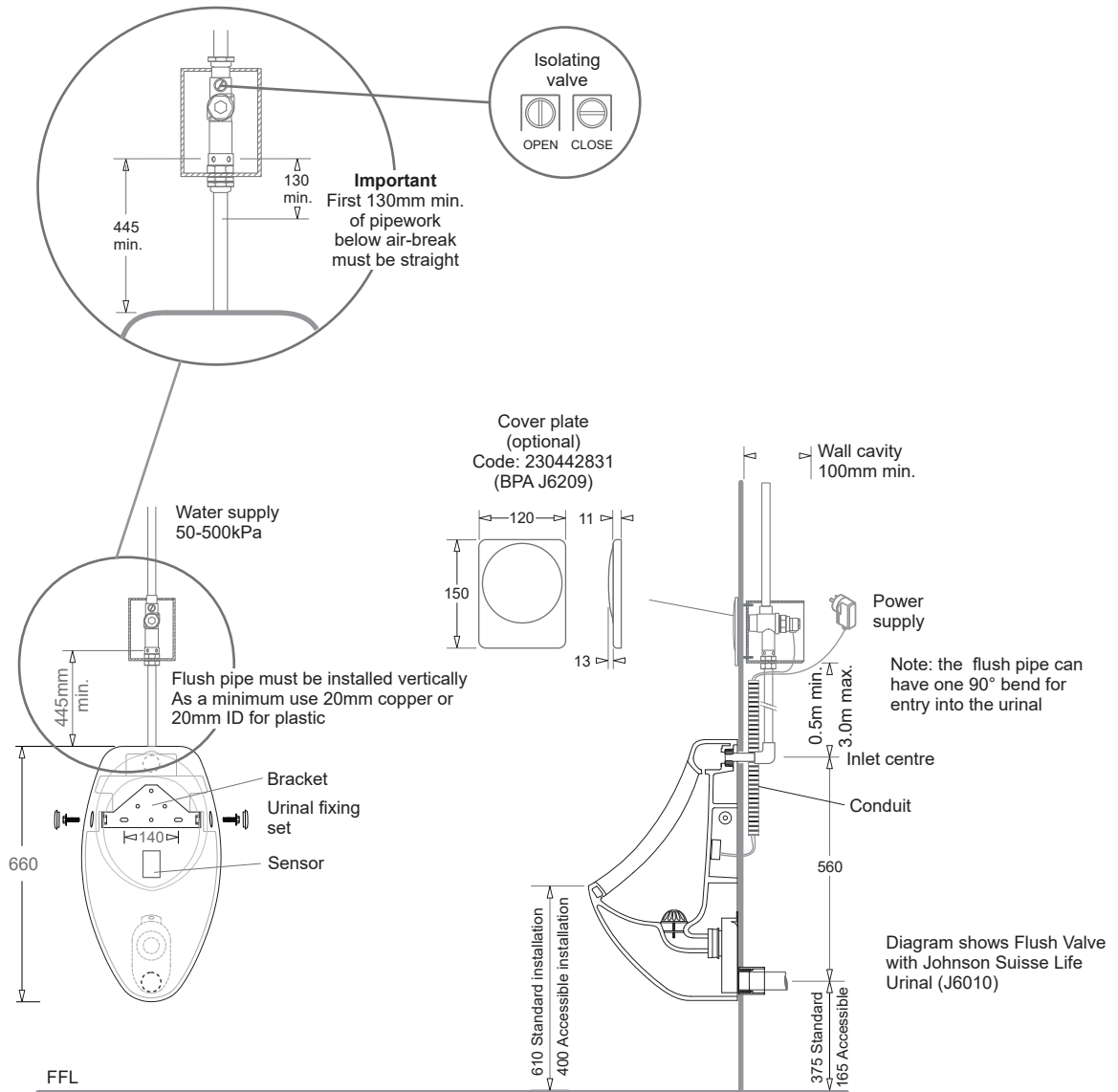

Note: Flush pipe must be vertical until the 90° bend at the urinal entry. There must be no other bends than this.

In-duct installation

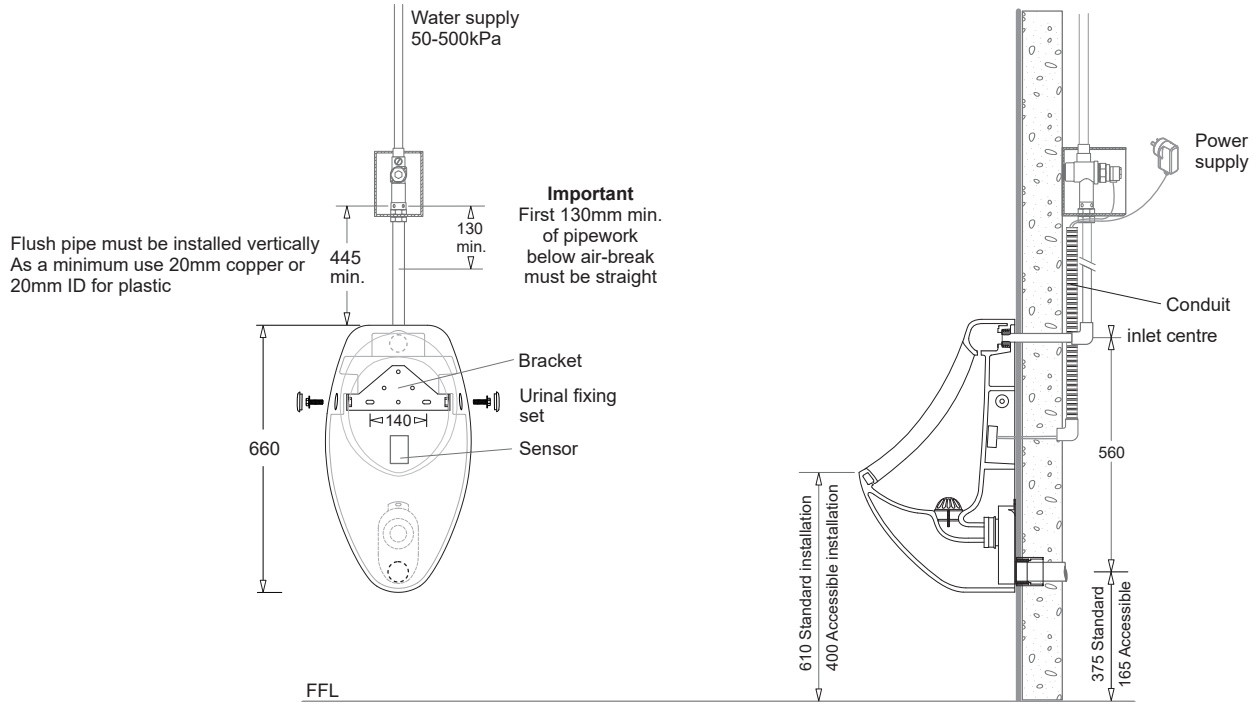

Note: Flush pipe must be vertical until the 90° bend at the urinal entry. There must be no other bends than this.

Ceiling installation

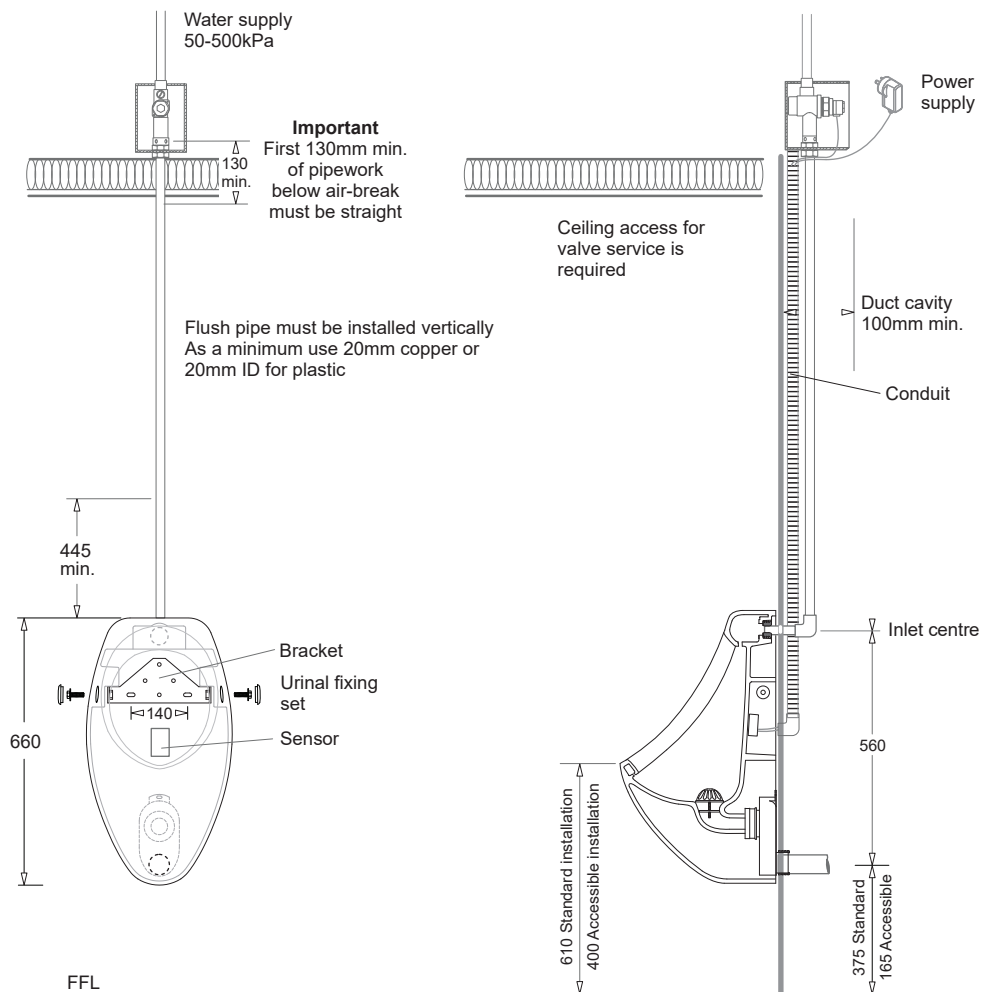

Note: Flush pipe must be vertical until the 90° bend at the urinal entry. There must be no other bends than this.



BQT Pty Ltd
PO Box 192, Carole Park, QLD 4300,
Australia
T 07 3274 6330
F 07 3276 8516
E admin@bqt.com.au

JohnsonSuisse
Bathroom Solutions

Bathroom Products Australia Pty Ltd
PO Box 728 Botany NSW 1455
T 1300 717 717
F 1300 746 480
www.johnsonsuiss.com.au

WARRANTY and SERVICE
For all Warranty and Service information visit:
www.johnsonsuiss.com.au